

# DirectDrive small:DDs9426H Brushless DD Motor

## Features:

- 3 Phase Outer Rotor Brushless Motor without hall sensor
- Low Speed, Large Torque
- Sealed Casing, Dust- proof design
- High Precision and High Performance
- Safe and Reliable, Running Smoothly
- Lightweight, Energy Saving
- Low Noise, Long Life

## Specifications:

Item No.	DDs 9426H ;Name	Brushless Disc Motor
Motor Type	Brushless DC/ Outer rotor/ No sensor	
Weight (g)	470 ;	Motor Dimension (DxL)( mm)94x26
Diameter of Hollow Shaft (mm)	12.6 ; Configuration	36N42P
Phase	3 ;	Number of pole pairs 21
Winding Type	WYE & Sinewave Back EMF	
Resistance (Ri) (Ohm)	13.4	
Rated power	320watt	
Recommended Voltage (V)	14.8- 60V	
Max. nominal Voltage (V)	100 V	
KV (RPM/V)	22	
No Load Current (A)	0.14	
Stall Current (A)	6.7 ; peak current	20A
Operating Temperature Range	-40 to +150 degree Celsius	
Torque N.m	1.89 N.m ; Peak Torque : 5.67 N.m.	
Inductance (mH)	26.2 mH	
Max. speed@48V	= 1080 rpm.	
Max. speed @72V	= 1690 rpm.	
Max. speed @84V	= 1890 rpm	

DDS9426H

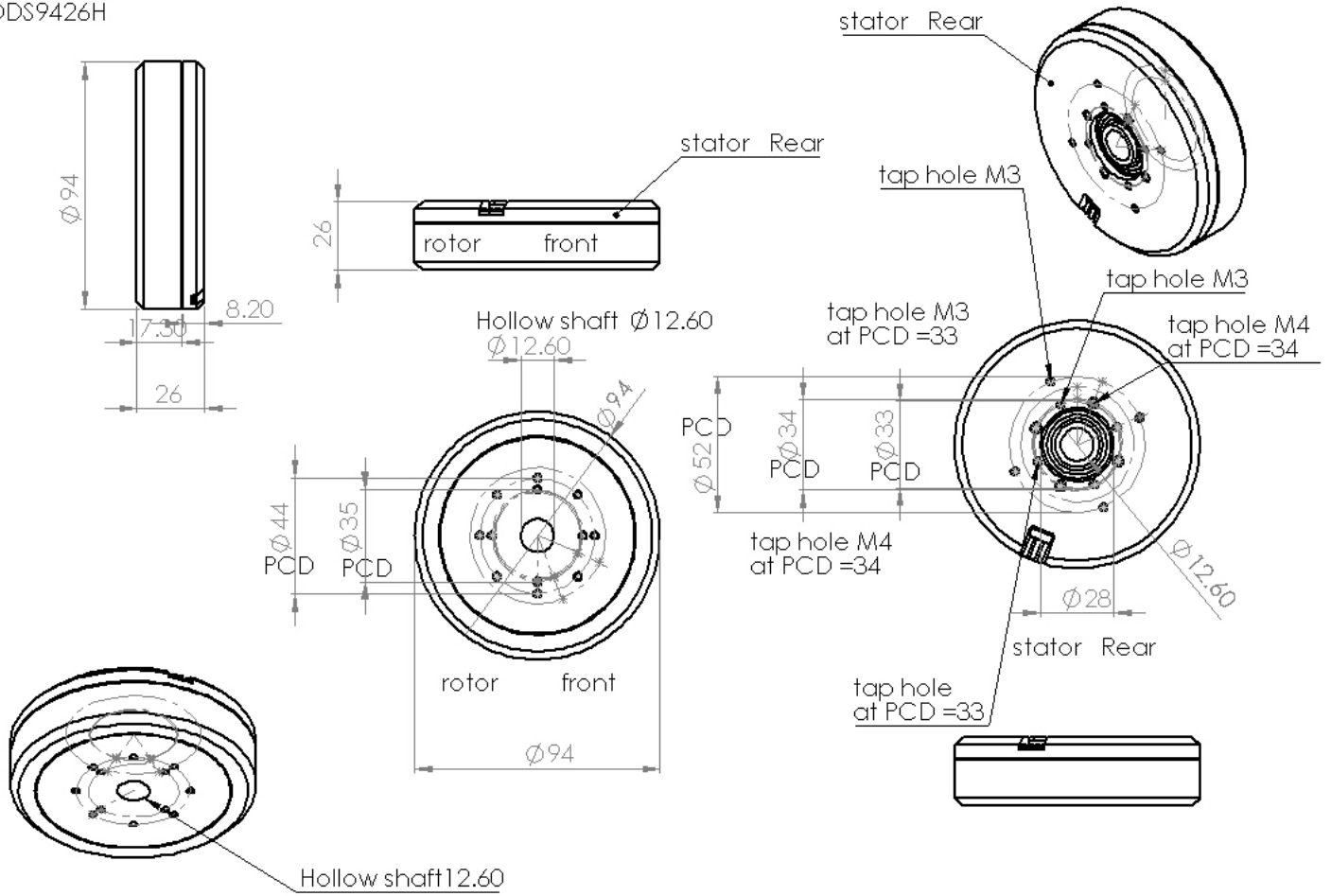

Assem Dds 9426\_Flange\_Encoder

**type 1**

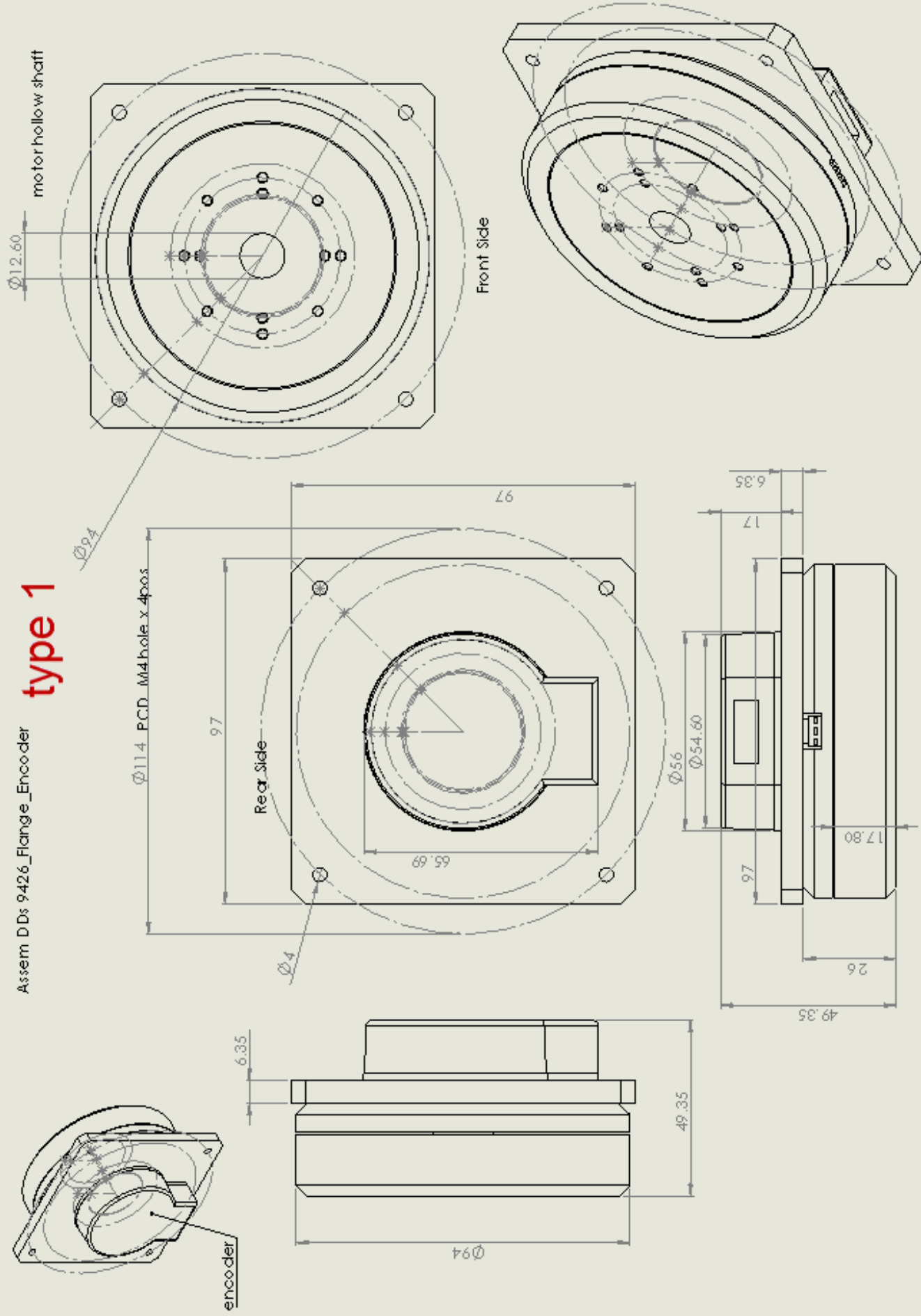

Assem Dds 9426\_Flange\_Encoder